

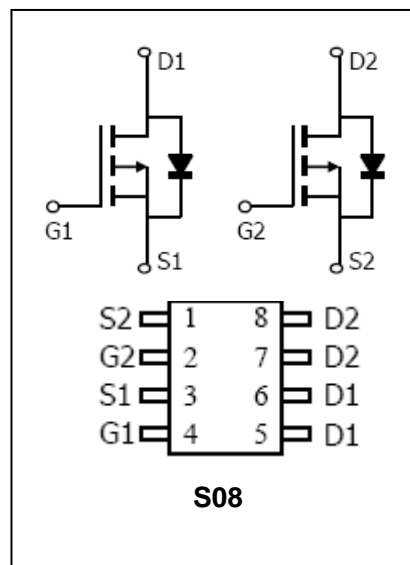

Dual P-Channel Enhancement Mode Field Effect Transistor BL4803

FEATURES

- $V_{DS} (V) = -30V$
- $I_D = -5 A (V_{GS} = -10V)$
- $R_{DS(ON)} < 52m\Omega (V_{GS} = -10V)$
 $R_{DS(ON)} < 87m\Omega (V_{GS} = -4.5V)$



APPLICATIONS

- P-channel enhancement mode effect transistor.
- Switching application.

ORDERING INFORMATION

Type No.	Marking	Package Code
BL4803	4803 010T	S08

MAXIMUM RATING @ Ta=25°C unless otherwise specified

Symbol	Parameter	Value	Units
V_{DSS}	Drain-Source voltage	-30	V
V_{GSS}	Gate -Source voltage	± 20	V
I_D	Continuous Drain Current ^A	@ TA = 25 °C -5 @ TA = 70 °C -4.2	A
I_{DM}	Pulsed Drain Current ^a	-20	A
P_D	Power Dissipation	@ TA = 25 °C 2 @ TA = 70 °C 1.4	W
$R_{\theta JA}$	Thermal resistance, Junction-to-Ambient	62.5	°C/W
T_J, T_{stg}	Junction and Storage Temperature	-55 to +150	°C



Dual P-Channel Enhancement Mode Field Effect Transistor BL4803

ELECTRICAL CHARACTERISTICS @ Ta=25°C unless otherwise specified

Parameter	Symbol	Test conditions	MIN	TYP	MAX	UNIT
STATIC PARAMETERS						
Drain-Source Breakdown Voltage	BV_{DSS}	$V_{GS}=0V, I_D=-250\mu A$	-30	-	-	V
Zero Gate Voltage Drain Current	I_{DSS}	$V_{DS}=-24, V_{GS}=0V$	-	-	-1	μA
Gate-body Leakage	I_{GSS}	$V_{DS}=0V, V_{GS}=\pm 20V$	-	-	± 100	nA
Gate Threshold Voltage	$V_{GS(th)}$	$V_{DS}=V_{GS}, I_D=-250\mu A$	-1	-1.8	-3	V
On state drain current	I_{DON}	$V_{DS}=-5V, V_{GS}=-4.5V$	-20	-	-	A
Static drain-Source on-resistance	$R_{DS(ON)}$	$V_{GS}=-10V, I_D=5.0A$	-	39	52	m Ω
		$V_{GS}=-4.5V, I_D=-4A$	-	67	87	
Forward Transconductance	g_{FS}	$V_{DS}=-5V, I_D=-5A$	6	8.6	-	S
Drain-Source diode forward voltage	V_{SD}	$V_{GS}=0V, I_s=-1A$	-	-0.77	-1	V
Maximum Body-Diode Continuous Current	I_s		-	-	-2.8	A
DYNAMIC CHARACTERISTICS^C						
Input capacitance	C_{ISS}	$V_{DS}=-15V, V_{GS}=0V, f=1.0MHz$	-	700	-	pF
Output capacitance	C_{OSS}		-	120	-	
Reverse transfer capacitance	C_{RSS}		-	75	-	
Gate resistance	R_g	$V_{DS}=0V, V_{GS}=0V, f=1.0MHz$		10		Ω
SWITCHING CHARACTERISTICS^C						
Turn-On Delay Time	$t_{D(ON)}$	$V_{DS} = -15V,$ $R_L = 3\Omega,$ $V_{GS} = -10V,$ $R_{GEN} = 3\Omega$	-	8.3	-	ns
Rise Time	t_r		-	5	-	ns
Turn-Off Delay Time	$t_{D(OFF)}$		-	29	-	ns
Fall Time	t_f		-	14	-	ns
Total Gate Charge(10V)	$Q_g(10V)$	$V_{DS} = -15V$ $I_D = -5A$ $V_{GS} = -10V,$	-	14.7	-	nC
Total Gate Charge (4.5V)	$Q_g(4.5V)$		-	7.6	-	nC
Gate-Source Charge	Q_{gs}		-	2	-	nC
Gate-Drain Charge	Q_{gd}		-	3.8	-	nC
Body Diode Reverse Recovery Time	t_{rr}	$I_F=-5A, dI/dt=100A/\mu s$	-	23.5	-	nS
Body Diode Reverse Recovery Charge	Q_{rr}	$I_F=-5A, dI/dt=100A/\mu s$	-	13.4	-	nC



Dual P-Channel Enhancement Mode Field Effect Transistor BL4803

TYPICAL CHARACTERISTICS @ $T_a=25^\circ\text{C}$ unless otherwise specified

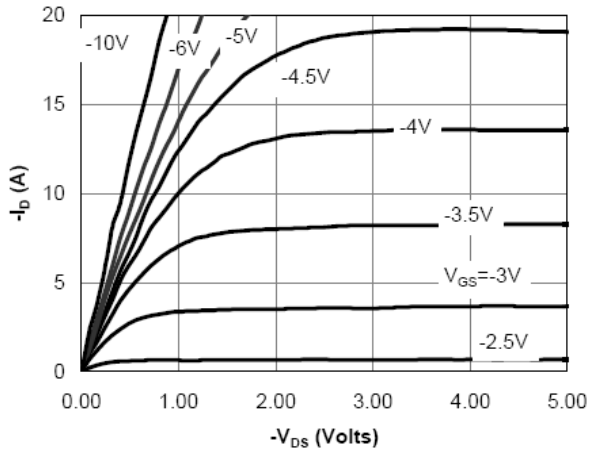

Figure 1: On-Region Characteristics

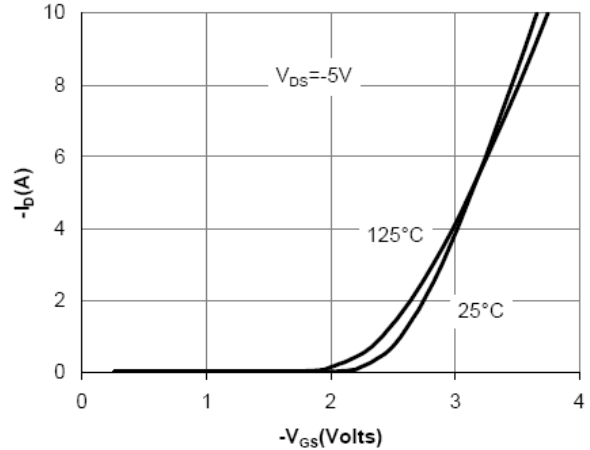

Figure 2: Transfer Characteristics

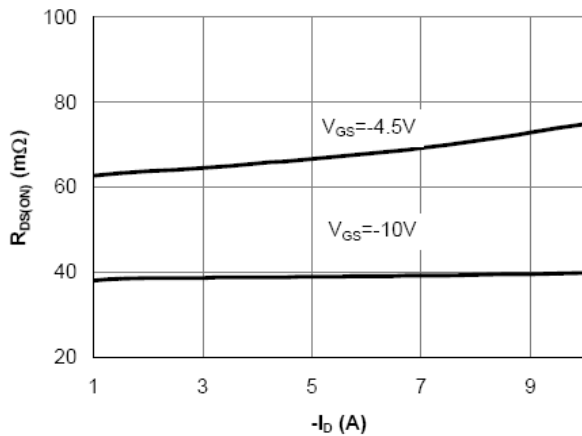

Figure 3: On-Resistance vs. Drain Current and Gate Voltage

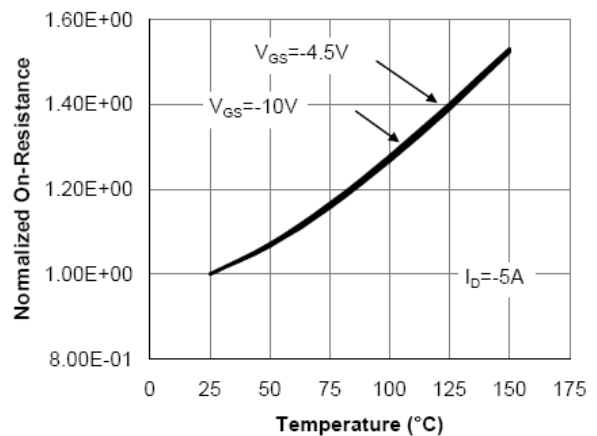

Figure 4: On-Resistance vs. Junction Temperature

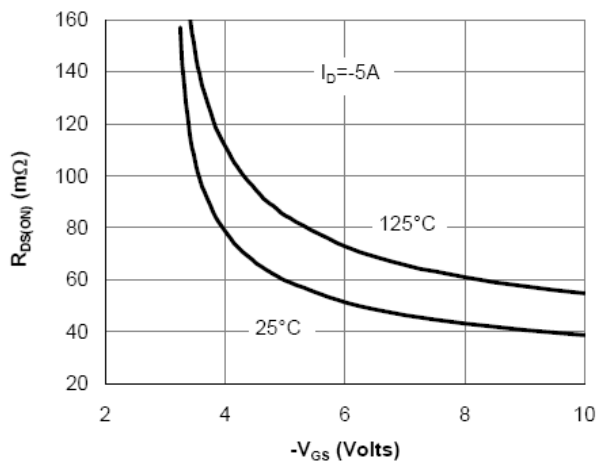

Figure 5: On-Resistance vs. Gate-Source Voltage

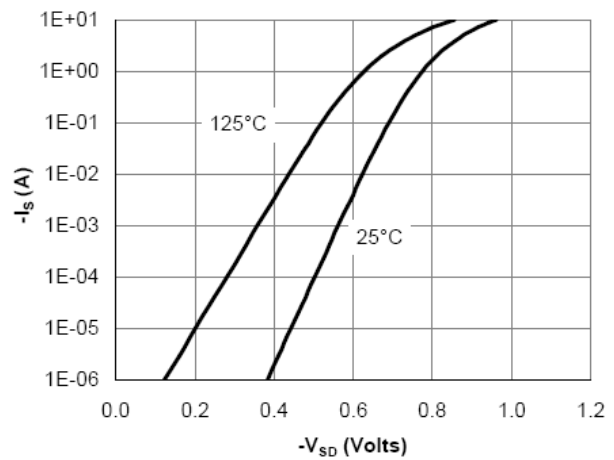

Figure 6: Body-Diode Characteristics

Dual P-Channel Enhancement Mode Field Effect Transistor BL4803

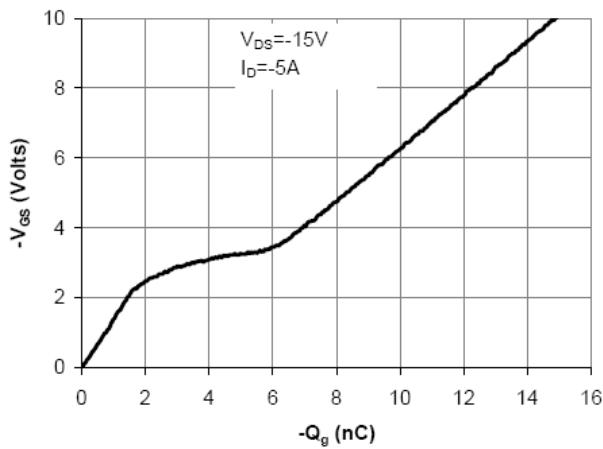

Figure 7: Gate-Charge Characteristics

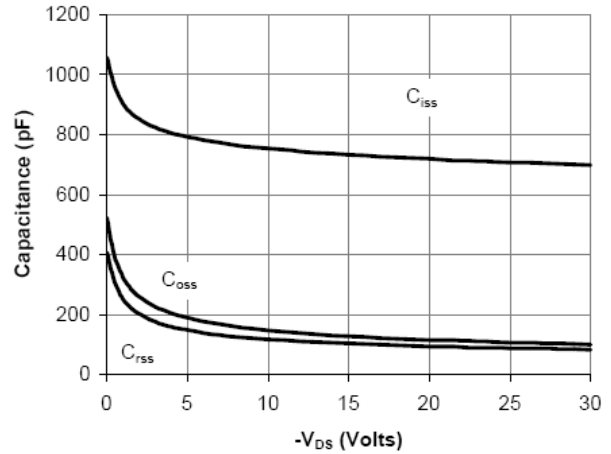

Figure 8: Capacitance Characteristics

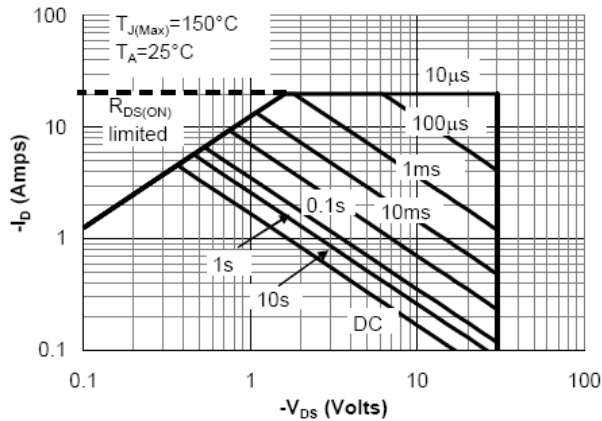

Figure 9: Maximum Forward Biased Safe Operating Area (Note E)

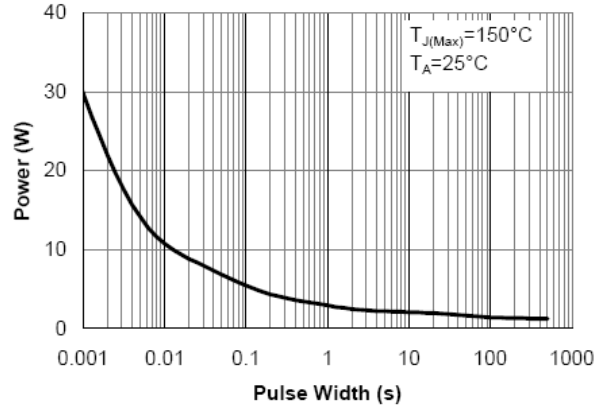

Figure 10: Single Pulse Power Rating Junction-to-Ambient (Note E)

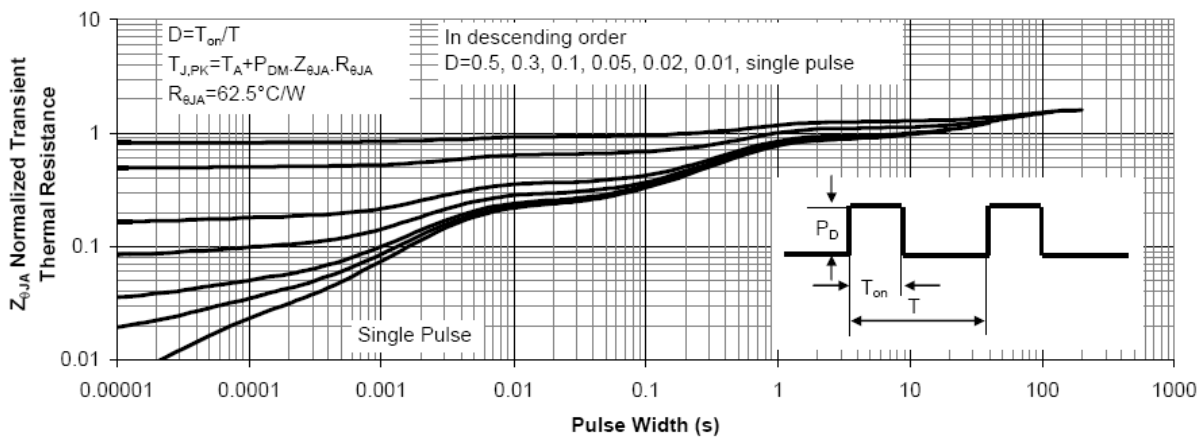

Figure 11: Normalized Maximum Transient Thermal Impedance